



Product Manual
Instructions for IRC-D6B Controller



Product Manual Instructions for Controller

V3.0

This manual is designed to provide you with product-related supporting information, and its content may be updated at any time without prior notice.

Agilebot strives to ensure the accuracy and timeliness of the manual's content, but the information contained therein does not constitute any express warranty or commitment by Agilebot.

Please note that Agilebot shall not assume any liability for any damages (including but not limited to direct, indirect, incidental, or consequential damages) that may arise from the use, reference, or reliance on the content of this manual.

Under no circumstances shall any part of this manual be reproduced or disseminated without Agilebot's prior written permission.

If you need additional copies of this manual, please contact Agilebot.

We apologize for any inconvenience caused during the use of this manual!

Note: This publication is based on the Chinese version.

This publication uses the International System of Units throughout, and GB represents the Chinese National Standard.

Revision

Ver.	Date	Status
V1.0	Fer.25,2025	Canceled
V2.0	Dec.25,2025	Canceled
V3.0	Jun. 1.2026	Released

Table of Contents

SAFETY INSTRUCTIONS	6
1 QUICK START	11
1.1 Summary	11
1.2 Unboxing Inspection	12
1.3 The appearance of the Controller and the operation handle.....	13
1.4 Introduction to the Functions of the Controller and the Operation Handle	15
1.5 Functions of the Buttons on the Operation Handle.....	16
2 DESCRIPTION OF ELECTRICAL INTERFACES	18
2.1 Introduction to the Front Panel Interfaces Inside the Controller	18
2.2 Controller I/O	19
2.3 Controller Communication Interfaces.....	33
3 MAINTENANCE AND REPAIR	35
3.1 Daily maintenance.....	35
3.2 Monthly maintenance	35
3.3 Maintenance tools	35
4 RESOLUTION OF COMMON FAULTS	36
4.1 Don’ t power on	36
4.2 When the handle cannot be powered on (the handle LED does not light up)	36
4.3 Alarm screen	36
4.4 Resolution of common faults based on alarm codes.....	38
5 REPLACEMENT OF UNITS	47
5.1 Steps before replacement.....	48
6 HANDLING AND MOUNTING	49
6.1 Handling method.....	49
6.2 Mounting method	50
6.3 Mounting conditions	51
6.4 Adjustment and confirmation items during mounting.....	51
APPENDICE	52
A. Meaning of control system I/O signals of peripheral devices.....	52
B. Spare Parts	54

SAFETY INSTRUCTIONS

It is necessary to read and understand the contents described in this chapter before using robots.

In this Manual, the robot system refers to an integrated system composing the body, controller, wired handle, cables, software and other accessories of the collaborative robot. When designing the robot system, the integrator must fully consider safety precautions for the user and the system and observe the safety requirements of the standards and regulations of relevant countries. Nobody is allowed to modify the collaborative robot without authorization from Agilebot Robotics Co., Ltd. Agilebot Robotics Co., Ltd. shall assume no responsibility for any damage to the industrial robot or its components due to the use of any other components (software, tools, etc.) not provided by Agilebot.

Agilebot Robotics Co., Ltd. assumes no responsibility for any consequences caused by misuse of the industrial robot. The misuse includes:

- Use the robot beyond the specified parameter range
- Use it as a carrier for humans or animals
- Use it as a climbing tool
- Use it in explosive environments
- Use it for medical and life-related applications

Besides safety precautions in this chapter, this Manual contains other safety instructions, which must be followed as well.



For safety issues uncovered in this Manual, please refer to the Safety Manual.

Definition of safety signs

This Manual includes safety warnings to ensure personal safety of the users and avoid any damage to the machine tool and describes them with "Danger" and "Warning" in the main text based on their importance in safety.

In addition, relevant additional descriptions are described as "Caution".

Before use, the user must thoroughly read the precautions described in "Danger", "Warning" and "Caution".

Identification	Definition
 Danger	It indicates dangerous situations possibly resulting in serious injury or death to the user during incorrect operation.
 Warning	It indicates dangerous situations possibly resulting in mild or moderate personal injury or property damage during incorrect operation.
 Caution	It provides additional descriptions outside the scope of danger or warning.

Please read this Manual carefully and keep it secure for easy reference at any time.

Definition of user

The operators are defined as follows:

- Operator
 - Perform power-on/off operation on the robot.
 - Start the robot program from the panel board.
- Robot Engineer
 - Operate the robot.
 - Perform teaching and programming debugging of the robot within its working range.
- Maintenance Engineer
 - Operate the robot.
 - Perform teaching of the robot within its working range.
 - Carry out maintenance (repair, adjustment, replacement) operations on the robot.

The "Operator" is not allowed to enter the working range of the robot.

The "Robot Engineer" and "Maintenance Engineer" can carry out operations within the working range of the robot

The operations within the working range of the robot include handling, setting, teaching, adjustment, maintenance, etc.

To carry out the operations within the working range of the robot, it is necessary to receive professional training on the robot.

When operating, programming and maintaining the robot, the operator, programmer and maintenance engineer must give a safety warning and wear at least the following protective articles.

- Work clothes suitable for operations
- Safety shoes
- Safety helmets
- Goggles



Warning

1. Ensure that robot arms and tools (or end-effector) are correctly and firmly bolted.
2. Ensure that the robot arms have sufficient spaces of free movement.
3. Ensure that safety measures and parameters have been established to protect the users based on risk assessment.
4. Never wear loose clothes or jewelry when operating the robots. Tie long hair (if any) behind your head when operating the robot.
5. Always keep your head and face outside the reach of the robot during operation.
6. Never enter the safe range of the robot or touch the operating robot if a safe range has been

determined by risk assessment.

7. The user must be aware of the position of the E-stop button.

Warnings and precautions related to operation of the controller



Warning

Warnings and precautions related to operation of the controller

1. IRC-D6B is a closed structure. During design, it is required to prevent dust, oil mist and other conductive foreign objects around the controller from entering its interior. Regardless of whether the controller is running or not, its airtightness may be lost if it is not locked properly, leading to a malfunction and even possible electric shock, leakage or fire due to insulation degradation.
2. Except for maintenance engineers, nobody is allowed to open the door of the controller. So, please lock it properly.
3. To prevent electric shock, do not power on the controller while the door is open.
4. Provide more than one emergency stop button within reach of the operator according to the system configuration.
5. Make sure to connect the ground wire when the controller is connected to the power source.



Safety warning label





Both the robot and the controller bear several safety and information labels, which contain important information related to the product. This information is very useful for all persons operating the robot system, e.g. during mounting, maintenance or operation.

The safety labels are only graphical and applicable to all languages.



Caution

It is required to observe the safety and health signs on the product label. In addition, it is also necessary to comply with the supplementary safety information provided by the system builder or integrator.

Sign	Description
	<p>Warning: Electric Shock</p> <p>Indicates a hazardous electrical condition that, if not avoided, could result in death or serious injury.</p>
	<p>Warning: Beware of hand crushing</p> <p>Moving your hand near moving parts may cause your hand or fingers to get caught between the shaft and the housing.</p>
	<p>Warning: High Temperature</p> <p>indicates a high temperature hazard on the surface, and non-contact and contact proximity may cause personal injury.</p>
	<p>Protective Earthing</p> <p>Grounding sign of controller.</p>

1 QUICK START

1.1 SUMMARY

This manual applies to the IRC-D6B control unit.

If you purchase the IRC-D6B-S Controller, the overall wiring method is similar to the IRC-D6B, but please note the differences between AC and DC power supply versions.

This manual describes the maintenance and connection of the IRC-D6B for robotic applications.

For English version, please refer to the official documentation.



Warning

Provide more than one (inclusive) emergency stop button within reach of the operator according to the system configuration. Please disconnect the power supply of the controller or press the emergency stop button when entering the range of motion of the robot.

Naming rules for robot controllers

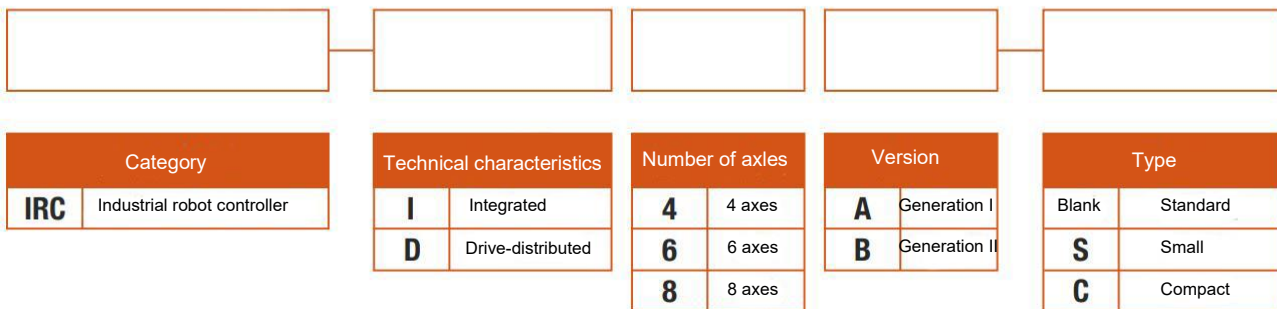

Schematic Diagram of the Robot System

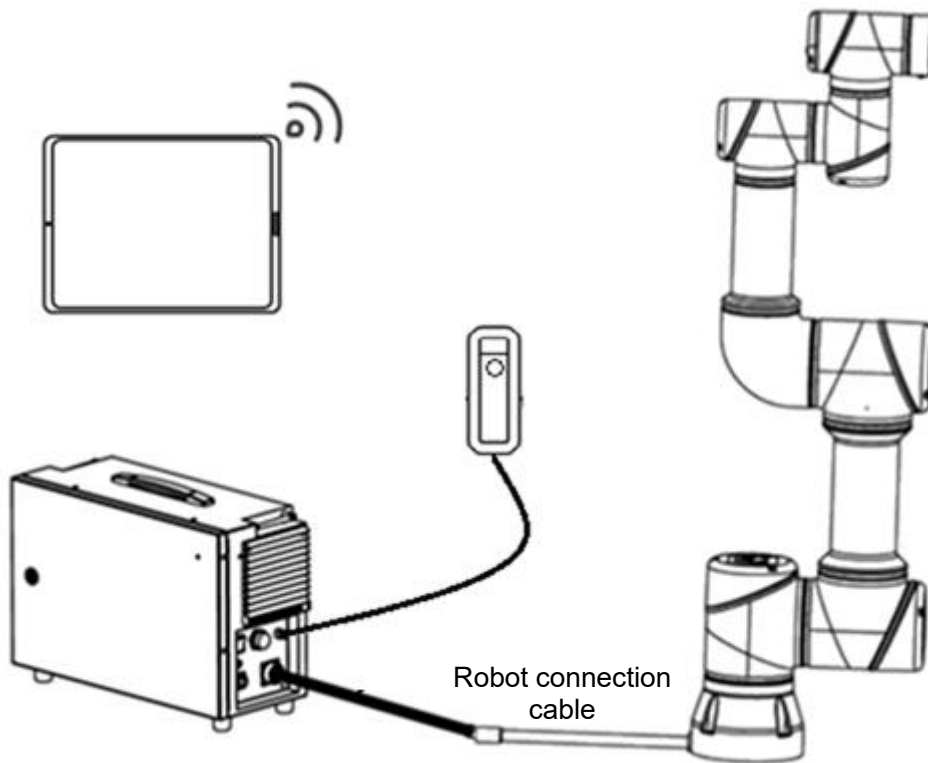

1.2 UNBOXING INSPECTION

1. Inspection of the Packing List

When you purchase a complete Agilebot C-series robot, the detailed packing list of the Controller you receive is as shown in the following table:

S/N	Name	Quantity
1	Controller and its key	1
2	Power cord of the Controller	1
3	Certificate of Conformity of Agilebot	1

2. Appearance Inspection of Components

S/N	Inspection Item
1	The nameplates of the Controller is well pasted, without abrasion or dirt, and the parameter contents on the nameplates are correctly matched.
2	The connectors and communication ports of the Controller are installed without looseness. There is no bending or missing of the metal pins, and no foreign matters. The appearance has no paint peeling or dirt. The marking traces of the cover plate screws are normal, and there is no opening trace.
3	There is no bending or missing of the metal pins of the power cord connector, and no foreign matters. There is no obvious indentation or folding trace on the outer rubber sheath of the cable.
4	The certificate of conformity is complete and clear.
5	The key of the Controller door has no damage.

1.3 THE APPEARANCE OF THE CONTROLLER AND THE OPERATION HANDLE

The appearance of the Controller



Fig. 1.1 Appearance of Controller

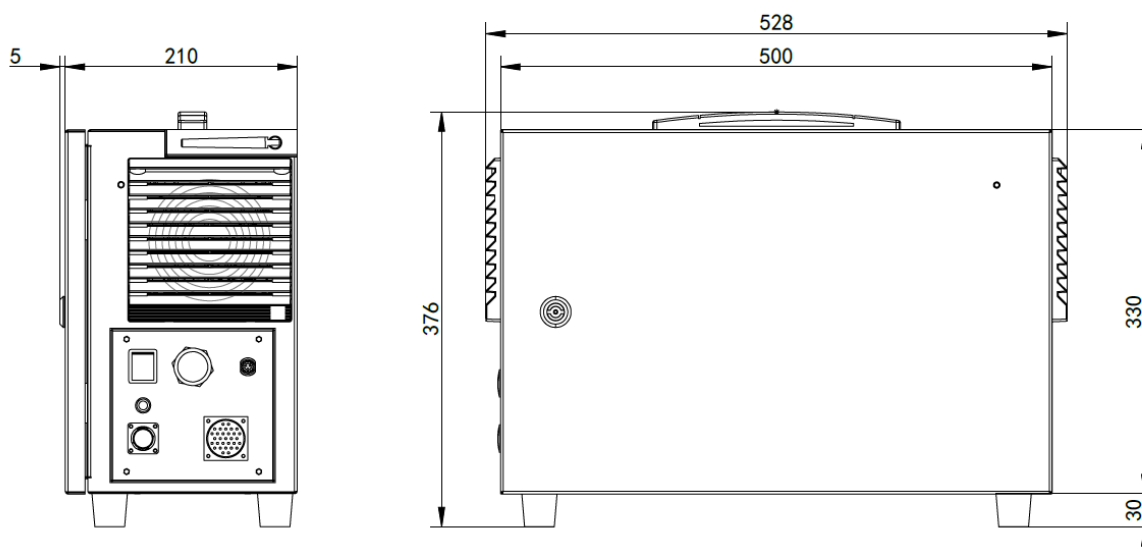

Figure 1.2 Schematic Diagram of the Dimensions of the Controller (Unit: mm)

The appearance of the operation handle (Inside the main unit packaging carton)



Fig. 1.3 Appearance of the operation handle

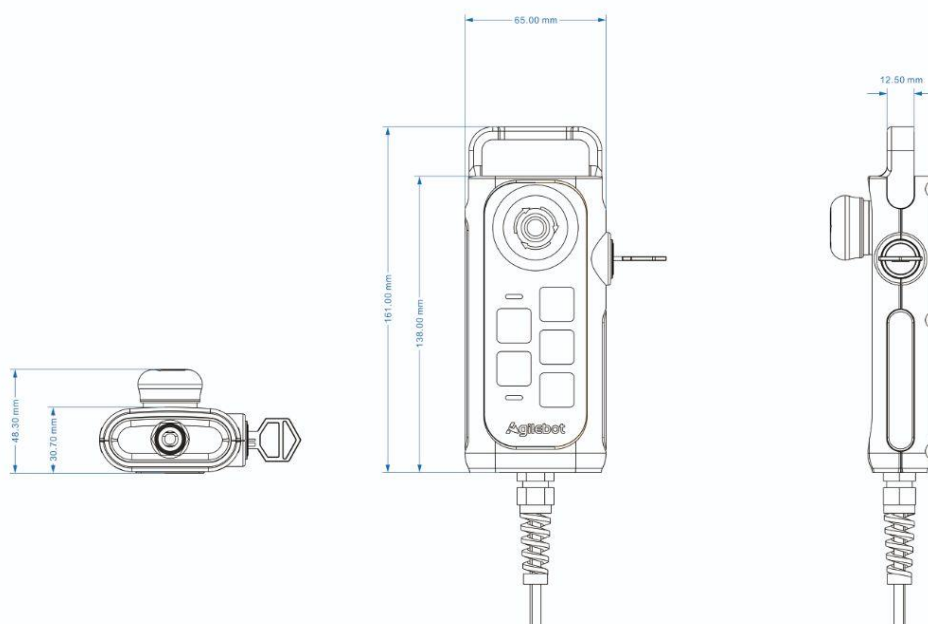

Figure 1.4 Schematic Diagram of the Dimensions of the Operation Handle(Unit: mm)

1.4 INTRODUCTION TO THE FUNCTIONS OF THE CONTROLLER AND THE OPERATION HANDLE

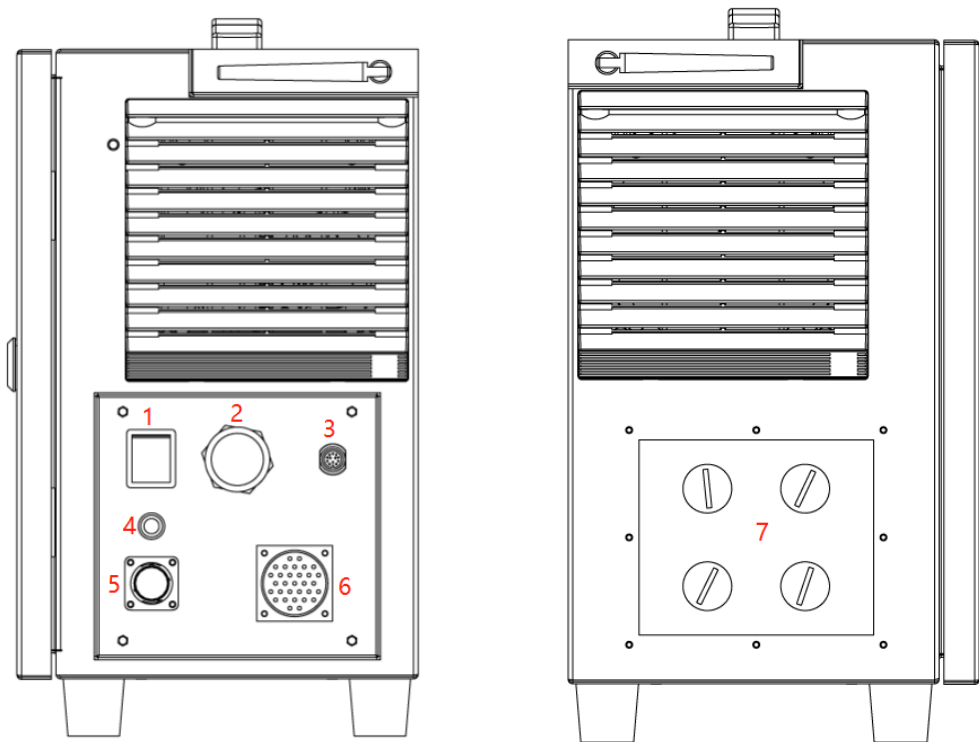

Figure 1.5 Functions of the Interface Panel

S/N	Name	Function
1	Switch	The switch of the Controller
2	Panel Network Port	The WLAN port, which is used as the communication interface for customers
3	Handle Interface	The connection interface for the operation handle
4	Status Indicator Light	It lights up when the Controller is powered on
5	Power Interface	The power supply interface of the Controller
6	RCC Interface	The interface for connecting with the main body
7	Expansion Panel	It is an expansion interface panel for customers, and the cable gland with a diameter of 20mm can be replaced by the customers themselves for use.

1.5 FUNCTIONS OF THE BUTTONS ON THE OPERATION HANDLE

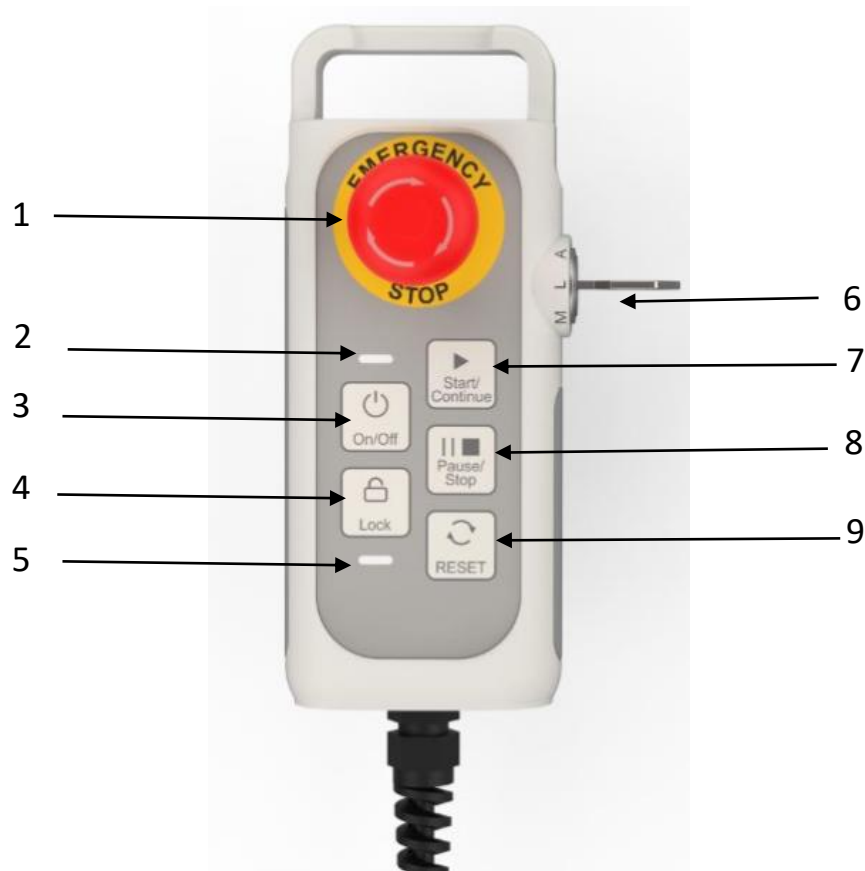

Figure 1.6 Schematic Diagram of the Buttons on the Operation Handle

S/N	Name	Function
1	E-stop	The robot immediately stops (Cat. 1 stop) when it is pressed.
2	Power light	Off: The Controller is not powered on. Blue breathing light: The main body is powering on. Steady white light: The main body has finished powering on but is not enabled. Green breathing light: The robot is enabled and in an idle state. Steady green light: The robot is running a program. Yellow breathing light: The program running on the robot is paused. Steady yellow light: The robot is being manually dragged. Fast - flashing red light: The robot startup timed out. You can try restarting it. Steady red light: The robot is in an emergency stop state.
3	On/Off	Press and hold for 3s to power on. Press and hold for 10s to shut down. Note: When shutting down, press and hold this button for 3s, a pop-up will appear on the operating terminal. Then, press Confirm to immediately shut down without waiting for 10s.
4	Lock key	Press and hold it for 3s to lock or unlock all buttons on the handle (except for e-stop and mode selector).

S/N	Name	Function
5	Lock light	It is on when the button is locked.
6	Mode switch	It is used to switch among Auto, Manual and LimitManual modes.
7	Start/Continue	Continuously run a program after its start or pause. The default program may be started when the mode selector is in AUTO. It can be designated in system configuration. Enter the editing interface of a program when the mode selector is in MANUAL. Press this button to run the program currently being edited. This button is irresponsive on other pages.
8	Pause/Abort	Press it to pause a running program, and press it again to abort the program.
9	Reset	Clear the error while enabling. However, RESET is invalid when the "forced drive" function is in effect.

2 DESCRIPTION OF ELECTRICAL INTERFACES

2.1 INTRODUCTION TO THE FRONT PANEL INTERFACES INSIDE THE CONTROLLER

The interfaces on the front panel of the Controller are arranged on the first layer after the Controller door is opened. They include user IO interfaces, emergency stop input interfaces, safety output interfaces, digital signal input interfaces, digital signal output interfaces, power selection interfaces, analog input/output interfaces, RS485 interfaces, encoder interfaces, and Ethernet ports. If necessary, you can contact Agilebot technical service personnel.

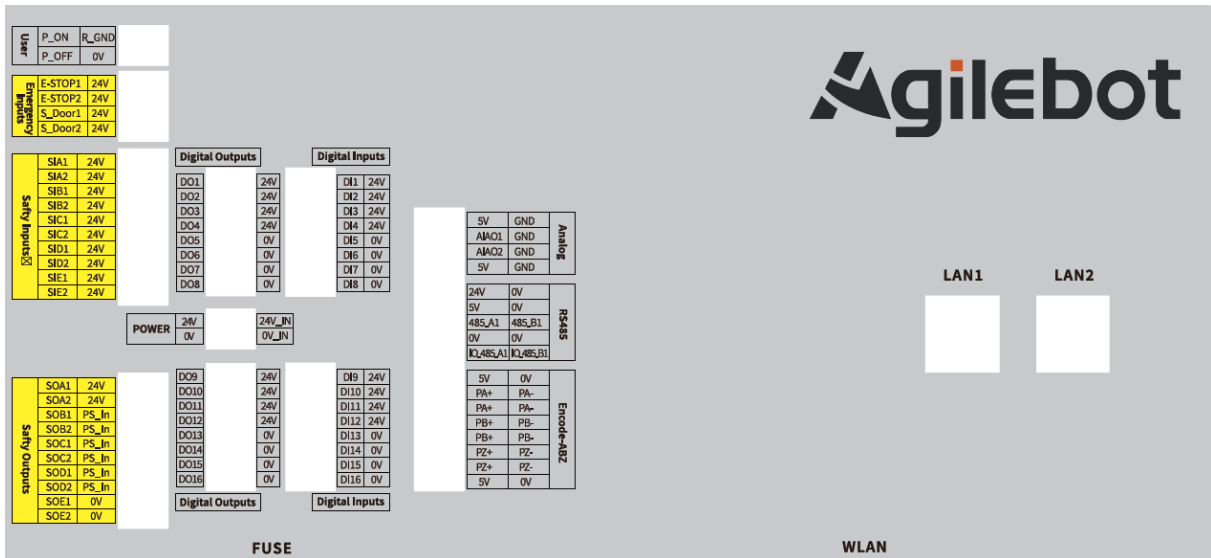

2.2 CONTROLLER I/O

You can use the I/O in the control box to control various devices, including pneumatic relays, PLCs, and emergency stop buttons.

The following figure shows the electrical interface group inside the control box.

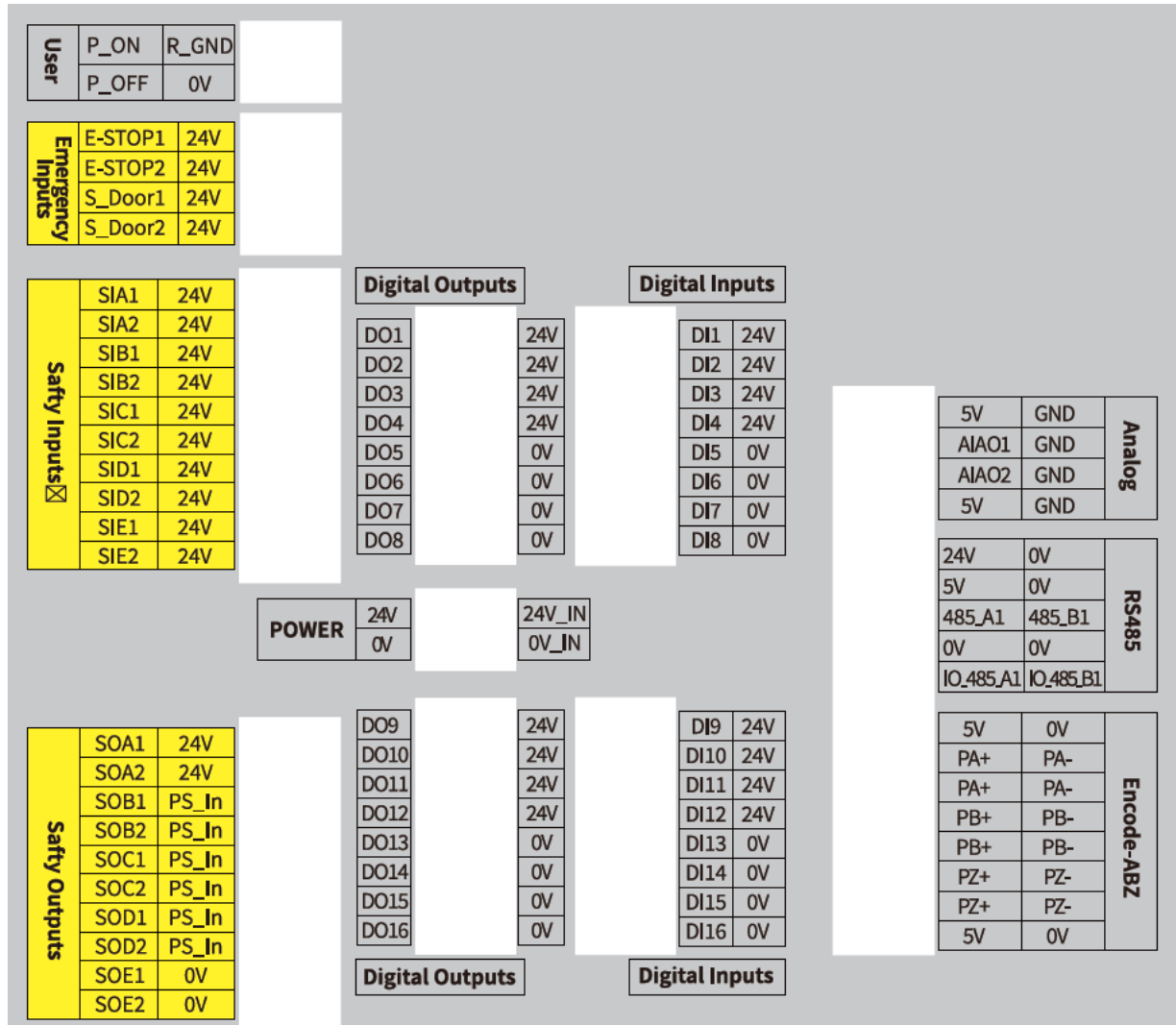

1、 User IO Interface

User	P_ON	R_GND
	P_OFF	0V

The user interface table is as follows:

User	
Signal Definition	Signal Definition
Power ON	R_GND
Power OFF	0V

It is used to power on and off the Controller; for remote power - on/off signal input, a high level (5 - 24V) is valid.

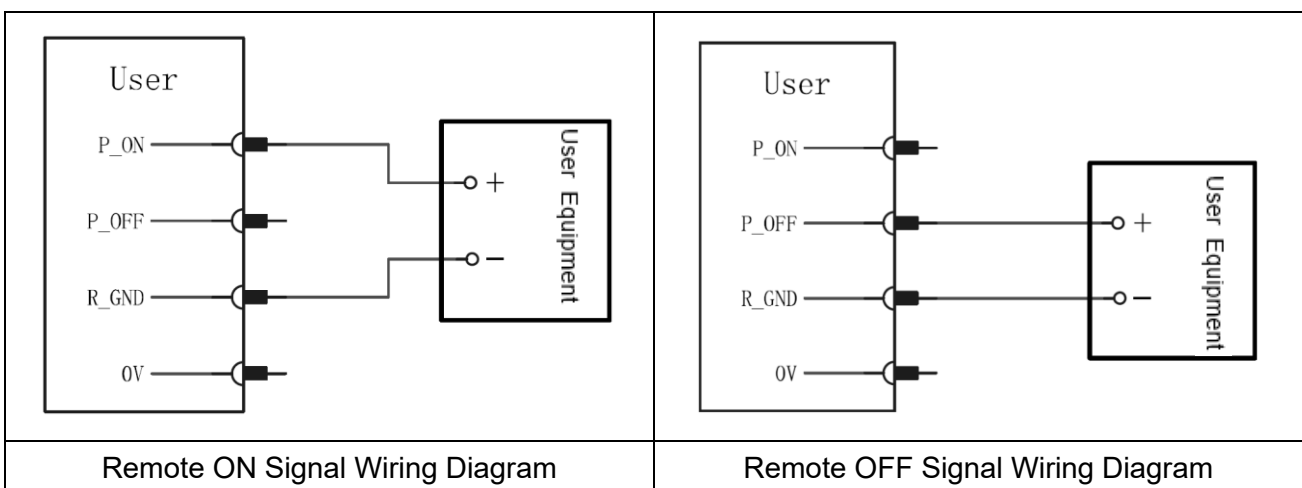

2、Emergency Stop Input Interface

Emergency Inputs	E-STOP1	24V
	E-STOP2	24V
	S_Door1	24V
	S_Door2	24V

The emergency stop input signal table is as follows:

Emergency Inputs	
Signal Definition	Signal Definition
Estop A Input	24V
Estop B Input	24V
SafedoorA Input	24V
SafedoorB Input	24V

The emergency stop input signal is a dual - loop input.

It is short - circuited by default at the factory (see the following figure).

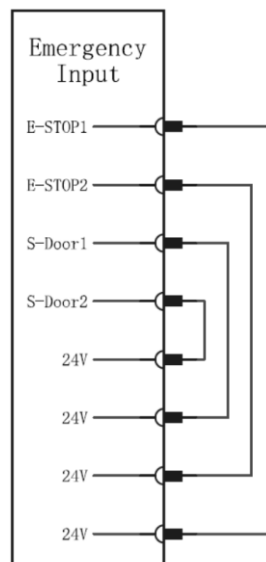

Connect the Emergency Stop Button (see the following figure).

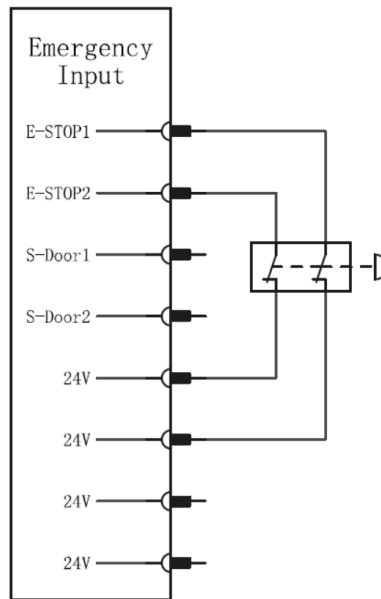

Connect the Emergency Stop Button(see the following figure).

This configuration is only for applications where the operator cannot pass through the door and close the door behind them. The configurable I/O is used to set a reset button outside the door to re - activate the robot's movement. When the signal is re - established, the robot automatically resumes movement.

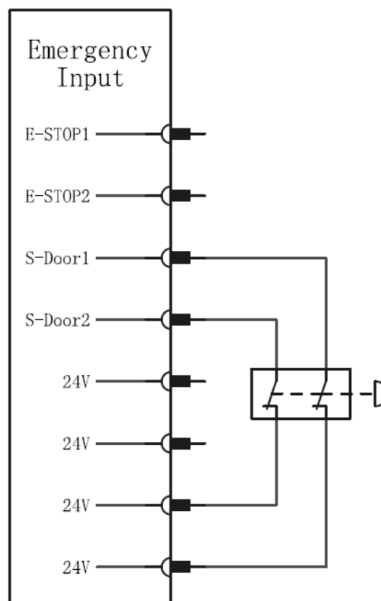

3、 Safety Output Interface

Safety Inputs ☒	SIA1	24V
	SIA2	24V
	SIB1	24V
	SIB2	24V
	SIC1	24V
	SIC2	24V
	SID1	24V
	SID2	24V
	SIE1	24V
	SIE2	24V

The safety output signal table is as follows:

Safety Outputs	
Signal Definition	Signal Definition
SOA1	24V+
SOA2	24V+
SOB1	PS_IN
SOB2	PS_IN
SOC1	PS_IN
SOC2	PS_IN
SOD1	PS_IN
SOD2	PS_IN
SOE1	GND
SOE2	GND

The safety output signal is a dual - loop output. The NPN/PNP hardware - switchable output is determined by PS_IN, and the output of the PS_IN interface will be sent to the SO signal.

For example, when configuring the three - position enable function, the wiring method is as shown in the following figure.

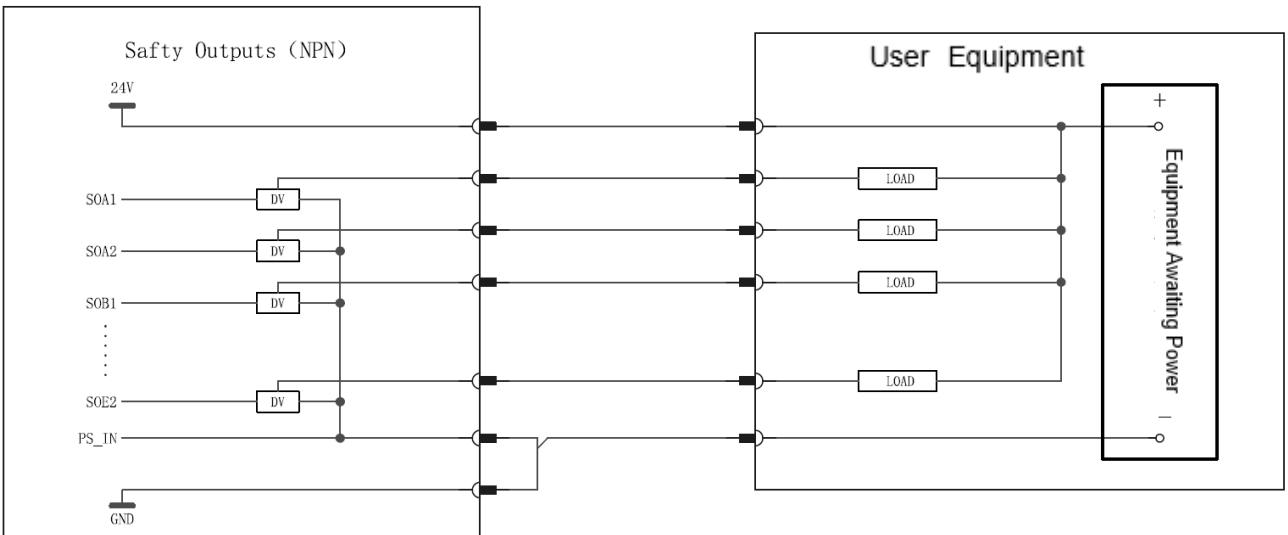
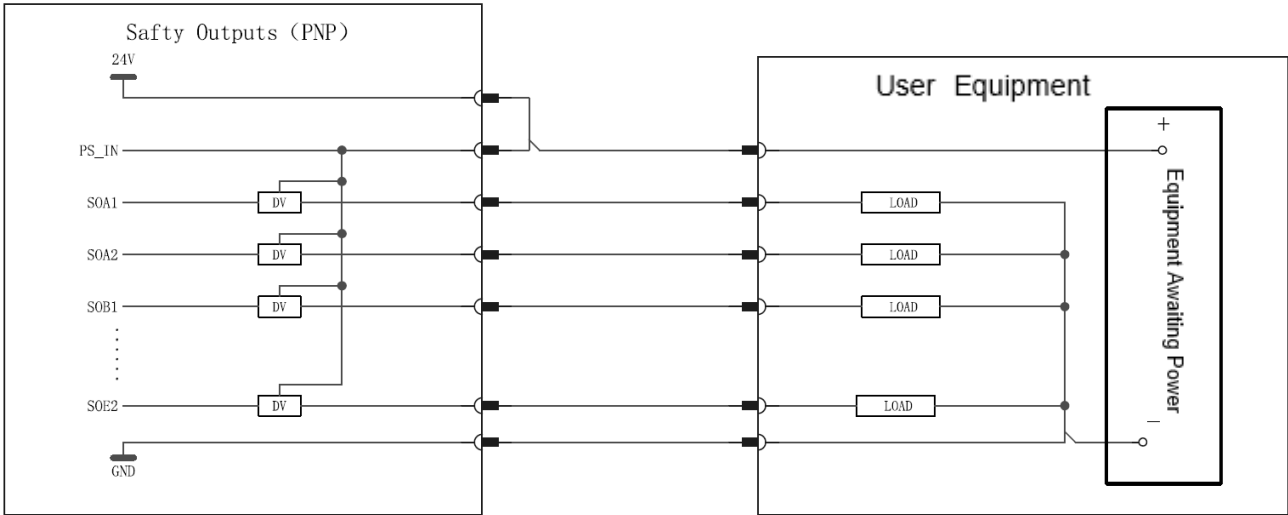

4、 Digital Signal Input Interface

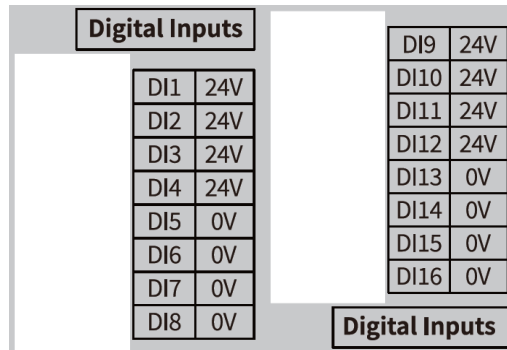

The signal input signal table is as follows:

Digital Inputs	
Signal Definition	Signal Definition
DI 1	24V
DI 2	24V
DI 3	24V
DI 4	24V
DI 5	0V
DI 6	0V
DI 7	0V
DI 8	0V
DI 9	24V
DI 10	24V
DI 11	24V
DI 12	24V
DI 13	0V
DI 14	0V
DI 15	0V
DI 16	0V

DI is switched by software. The right - hand side interface is only for power supply, and the power supply of the right - hand side interface is connected to the power selection interface (see the following figure).

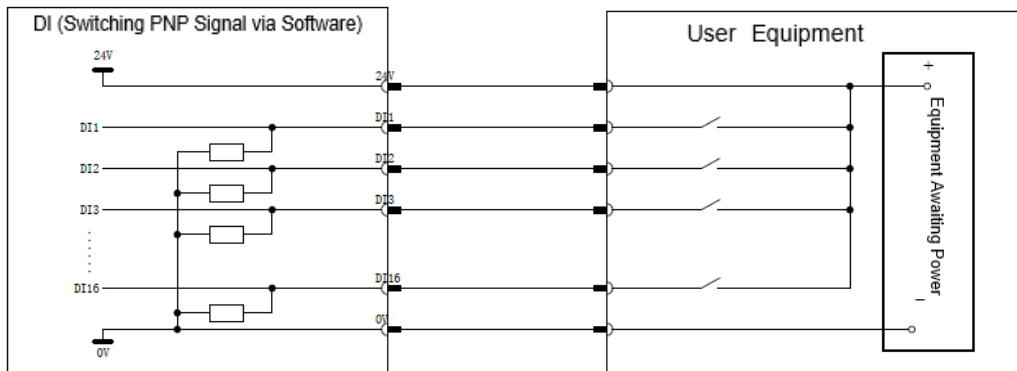
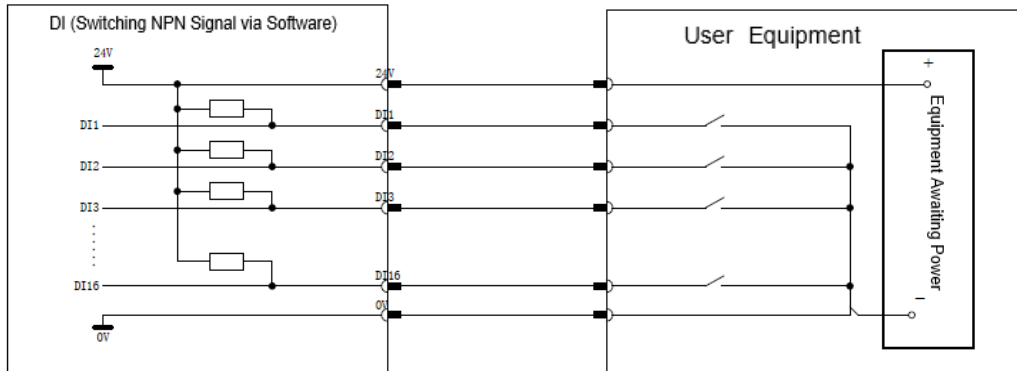

5、 Digital Signal Output Interface

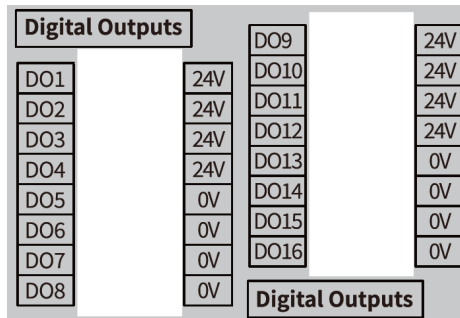

The signal output signal table is as follows:

Digital Outputs	
Signal Definition	Signal Definition
DO 1	24V
DO 2	24V
DO 3	24V
DO 4	24V
DO 5	0V
DO 6	0V
DO 7	0V
DO 8	0V
DO 9	24V
DO 10	24V
DO 11	24V
DO 12	24V
DO 13	0V
DO 14	0V
DO 15	0V
DO 16	0V

DO is switched by software. The right - hand side interface is only for power supply, and the power supply of the right - hand side interface is connected to the power selection interface (see the following figure).

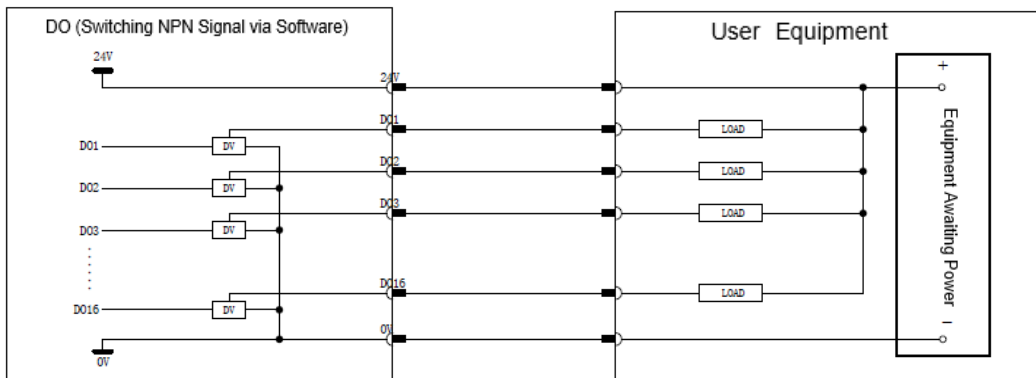
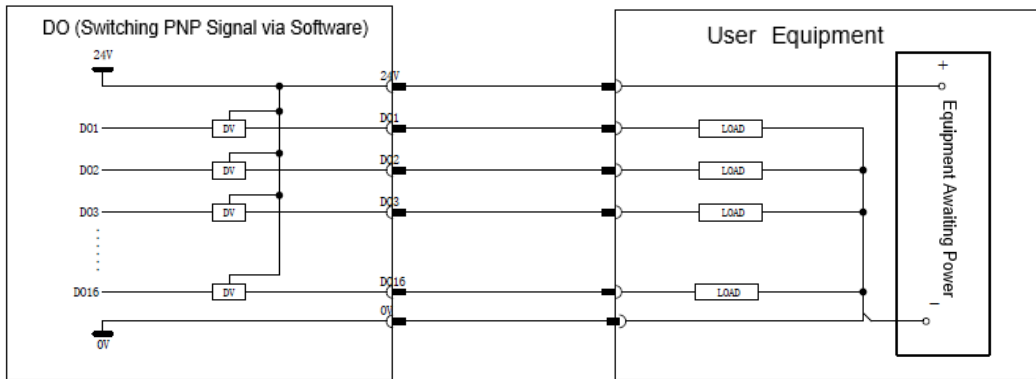

6、 Power Selection Interface

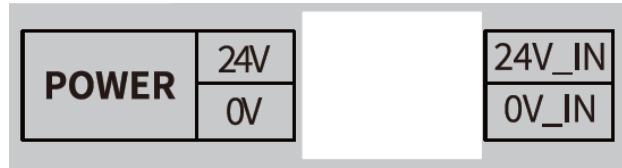

POWER	
Signal Definition	Signal Definition
24V_IN	24V
0V_IN	0V

The power selection interface supplies power to all signals on the wiring panel except safety signals according to the power supply situation selected by this interface. If there is no short - circuit or external power supply, the panel will have no signal output.

By default at the factory, 24V_IN is short - circuited with 24V, and 0V_IN is short - circuited with 0V, that is, internal power supply is used. When using internal power supply, the maximum output current is 2A.

If customers need a larger current supply, they need to connect the 24V and 0V of the customer's switching power supply to the left - hand side IN port (see the following figure).



Warning

It is strictly prohibited to short-circuit the customer's power supply with the power supply interface on the right side.

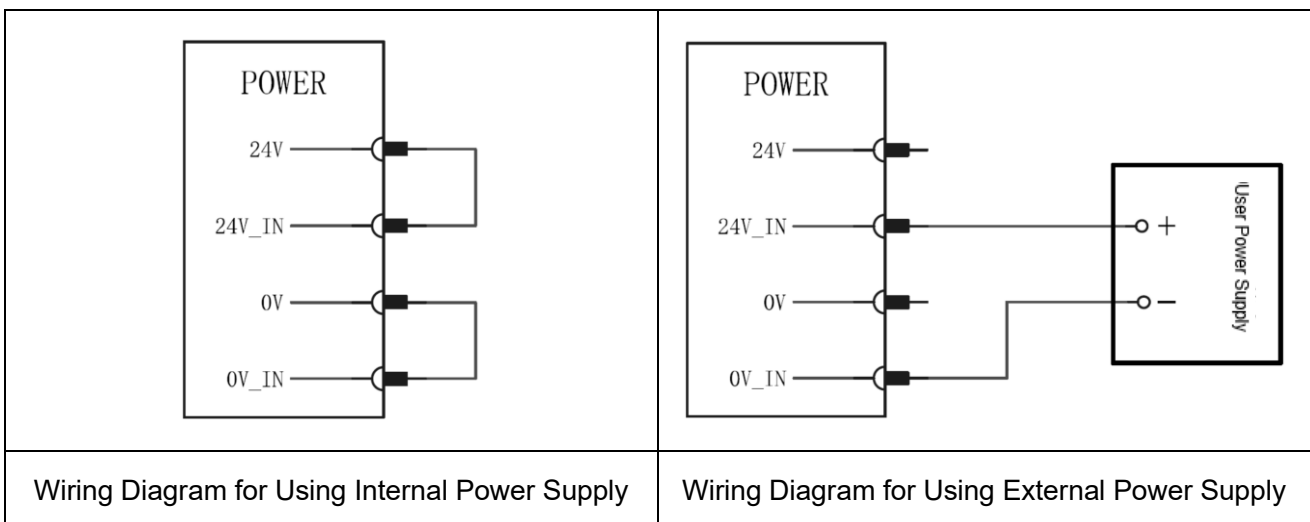

7、 Analog Input/Output Interface

5V	GND	Analog
AIAO1	GND	
AIAO2	GND	
5V	GND	

The analog input interface table is as follows:

Analog	
Signal Definition	Signal Definition
5V	0V
AI1	0V
AI2	0V
5V	0V

There are a total of 2 AIAO channels;

It has 2 analog input/output interfaces (Ch1, Ch2), and the mode is configurable;

Current signal input: 4 - 20mA;

Voltage signal input: 0 - 10V;

Current signal output: 0 - 20mA;

Voltage signal output: 0 - 10V

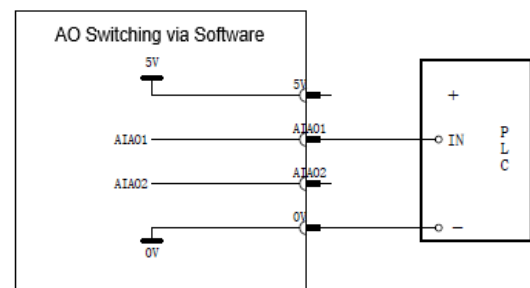
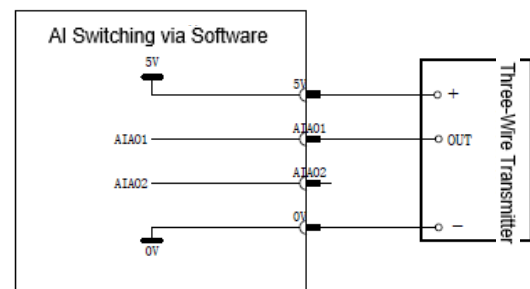
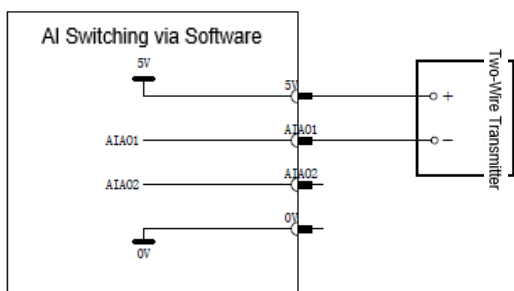

8、RS485 Interface

24V	0V	RS485
5V	0V	
485_A1	485_B1	
0V	0V	
IO_485_A1	IO_485_B1	

The RS485 interface table is as follows:

RS485	
Signal Definition	Signal Definition
24V	0V
5V	0V
485_A1	485_B1
0V	0V
IO_485_A1	IO_485_B1

Note: The 24V & 5V power supply interfaces cannot exceed 500MA.

It is used for Modbus RTU bus protocol processing.

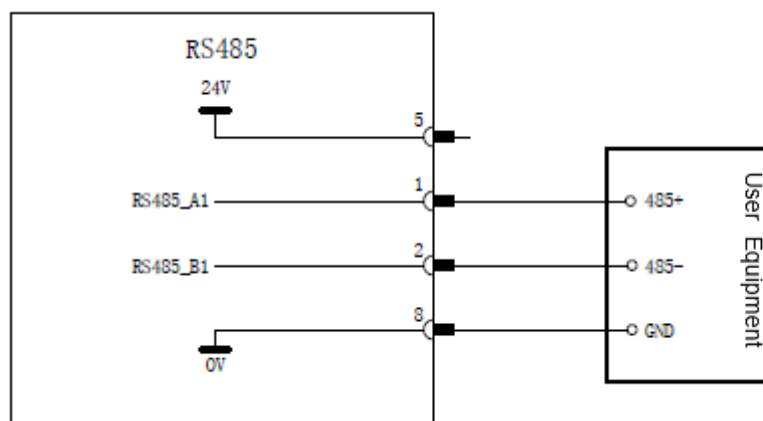

9、Encoder Input Interface

5V	0V	Encode-ABZ
PA+	PA-	
PA+	PA-	
PB+	PB-	
PB+	PB-	
PZ+	PZ-	
PZ+	PZ-	
5V	0V	

The encoder input interface table is as follows:

Encode-ABZ	
Signal Definition	Signal Definition
5V	0V
PA+	PA-
PA+	PA-
PB+	PB-
PB+	PB-
PZ+	PZ-
PZ+	PZ-
5V	0V

2.3 CONTROLLER COMMUNICATION INTERFACES



Caution

For the usage conditions of the network construction or devices other than the robot control device (such as HUBs, transceivers, cables, etc.), please consult the respective device manufacturers. When laying the network, it should be fully considered that it will not be affected by other noise sources. The noise sources such as power lines and motors should be electrically separated from the network wiring to a sufficient extent, and it is necessary to properly connect the ground wires for each device. In addition, it should be noted that if the grounding impedance is high and insufficient, it may sometimes lead to communication failures. Before the official operation after the device is installed, a communication test should be carried out for confirmation.

We cannot guarantee the normal operation of network failures caused by devices other than the robot control device.

Local Area Network Interface (LAN)

Location: There are two LAN interfaces on the front panel inside the Controller.

Function: It is used to connect internal network devices such as laptops, desktop computers, and printers to achieve data transmission and resource sharing within the local area network.

Purpose: Through the LAN interface, users can conduct efficient communication between devices within the local area network, supporting functions such as file sharing and printing services.

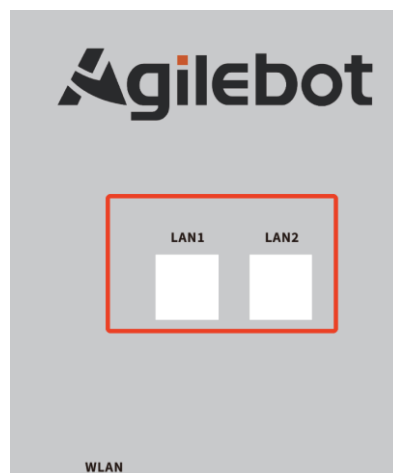

Wide Area Network Interface (WAN)

Location: There is a WAN interface at the bottom of the front panel of the Controller.

Function: It is used to connect external network devices such as modems (cable modems/optical modems), etc., and serves as the only channel for the router to communicate with the external network.

Purpose: Through the WAN interface, the Controller can communicate with the external network to achieve Internet access and other remote connection functions.

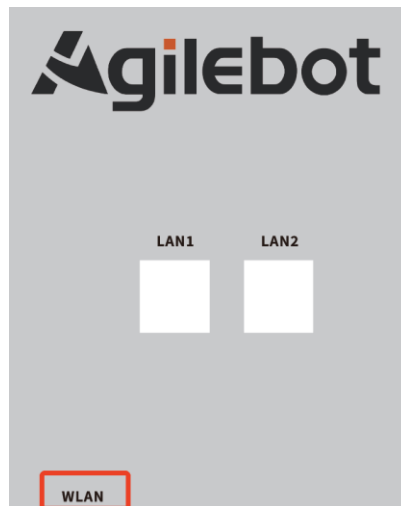

3 MAINTENANCE AND REPAIR

It is possible to maintain the performance of the robot in a long-term stable state through daily maintenance, regular maintenance and regular repair.

3.1 DAILY MAINTENANCE

During daily operation of the system, clean and repair all parts, check for cracks or damage on each part and conduct maintenance for the following items at any time.

Before running:

Confirm if the wired handle cable is excessively twisted. Please confirm if the controller and peripheral devices are abnormal.

After running:

Return the robot to the appropriate position and cut off the power supply to the controller after running. Confirm whether there are cracks or damages while cleaning and maintaining various parts. Clean excessive dust (if any) attached to the vent of the controller.

3.2 MONTHLY MAINTENANCE

- 1) Confirm if the fan rotates normally. Clean excessive dust and other impurities (if any) adhering to the fan.
- 2) Clean the dust from the interior of the controller. Wipe off any dust adhering to the fan and the transformer.
- 3) Confirm that an alarm is detected after the emergency stop is input, or stop and reset the controller to confirm normal startup in order to confirm normal operation of safety functions.
- 4) Check for any abnormal stains inside the controller. If any, please identify the cause and take necessary measures to clean them. Please check for any gaps around the sealing gasket in the locked state. Check for any gaps around the cable port.

3.3 MAINTENANCE TOOLS

It is recommended to prepare the following measuring instruments as maintenance tools: AC/DC voltmeter (sometimes, a digital voltmeter is required)

- 1) Measuring instrument: AC/DC voltmeter (sometimes, a digital voltmeter is required)
- 2) Oscilloscope: (frequency bandwidth above 5MHz, dual channel)
- 3) Tools: Phillips screwdriver, slotted screwdriver, socket screwdriver, wire pliers, scissors and tweezers.

4 RESOLUTION OF COMMON FAULTS

4.1 DON'T POWER ON

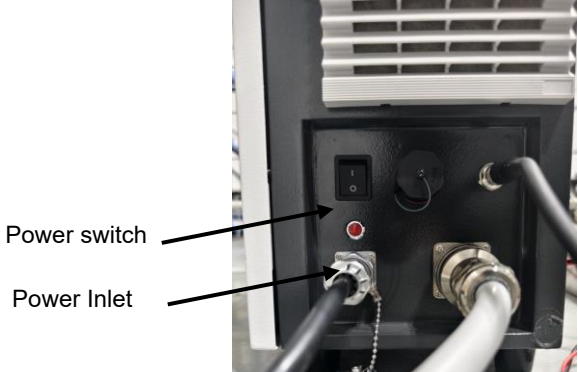
Inspection and treatment	Diagram
<p>Inspection 1: Confirm that the circuit breaker has been switched on.</p> <p>Treatment 1: Check whether the circuit breaker is switched on..</p> <p>Treatment 2: Check if the AC220V power cable is properly connected.</p>	

4.2 WHEN THE HANDLE CANNOT BE POWERED ON (THE HANDLE LED DOES NOT LIGHT UP)

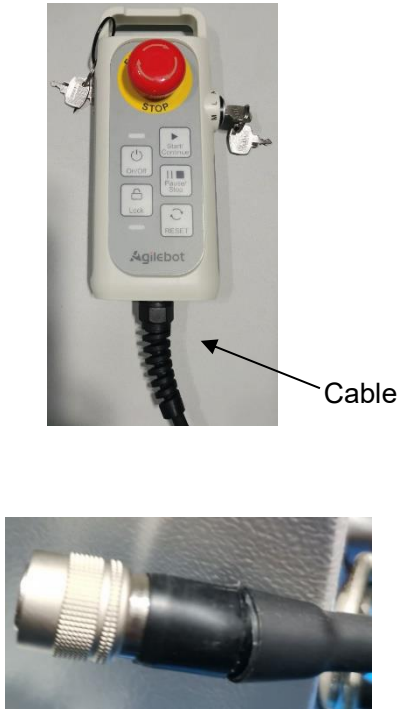
Inspection and treatment	Diagram
<p>Inspection 1: Confirm if the handle cable is damaged.</p> <p>Inspection 2: Confirm if the pin of the handle port is damaged.</p> <p>Treatment 1: Check if the cable is damaged and replace it if damaged.</p> <p>Treatment 2: Check if the pin is damaged and replace it if damaged.</p>	

4.3 ALARM SCREEN

Check if the robot currently has alarms and view the alarm history by the following operations.

1. In the main screen of the operating terminal, click on the character in the red box in Fig. 4.1 to

pop up the screen as shown in Fig. 4.2.

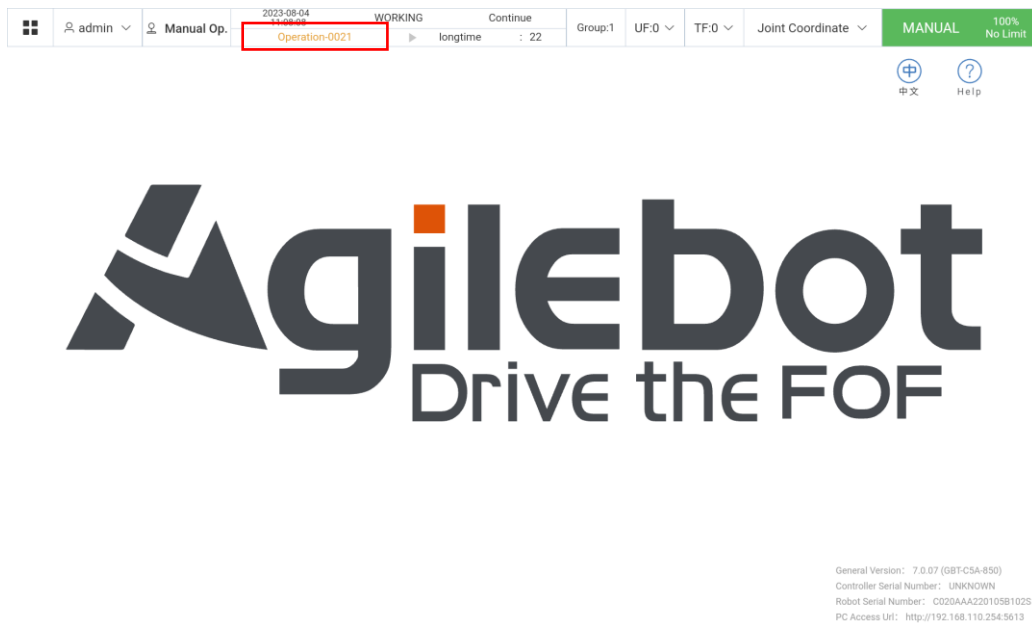

Fig.4.1 Main Screen of Operating Terminal

2. Click on the historical event to see the current alarm log and view the alarm history, as shown in Fig.4.3.

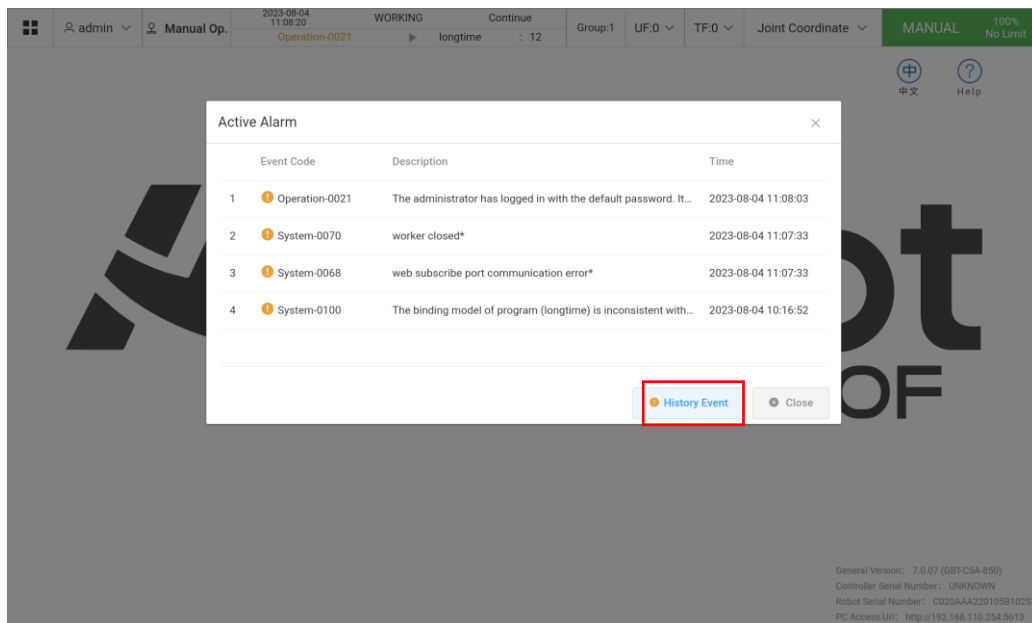

Fig.4.2 Current Alarm Popup

3. After viewing historical events, you can see various alarm codes and other messages. Click on the red box in Fig.4.3 to filter the alarm types.

Event Code	Description	Time
1	Operation-0021 The administrator has logged in with the default password. It is recommended to update the password*	2023-08-04 11:08:03
2	Operation-0017 admin login success*	2023-08-04 11:08:03
3	Operation-0065 user mode switching to UnlimitedManual*	2023-08-04 11:07:50
4	System-2196 TpComm logrun /rpc/tp_comm/getPublishTable success*	2023-08-04 11:07:50
5	System-2196 TpComm logrun /rpc/tp_comm/getRpcTable success*	2023-08-04 11:07:49
6	System-0069 Establish communication with control cabinet	2023-08-04 11:07:49
7	System-0070 worker closed*	2023-08-04 11:07:33
8	System-0068 web subscribe port communication error*	2023-08-04 11:07:33
9	System-0070 worker closed*	2023-08-04 10:37:37
10	System-2196 TpComm logrun /rpc/tp_comm/getPublishTable success*	2023-08-04 10:25:27

Fig. 4.3 Alarm History Screen

- After filtering the alarm types, you can see corresponding alarm messages as shown in Fig. 4.4.

Event Details

Operation-0021 (WARNING) 2023-08-04 11:08:03

ADMIN_LOGIN_WITH_DEFAULT_PASSWORD

Event Description
The administrator has logged in with the default password. It is recommended to update the password*

Consequence

Cause

Solution

[Previous](#) [Next](#)

Fig. 4.4 Alarm Information

4.4 RESOLUTION OF COMMON FAULTS BASED ON ALARM CODES

Motion-A32097 - UI servo enable is off*

Phenomenon: UI servo enable is off

Result: Stop

Cause: triggered by UI signal

Countermeasure: Keep the UI signal at a high level. Otherwise, the low level may trigger a Cat. 0 stop.

- (1) To view the UI signal, click the menu at the upper left corner of the screen, as shown in the following figure, and then click the communication screen.

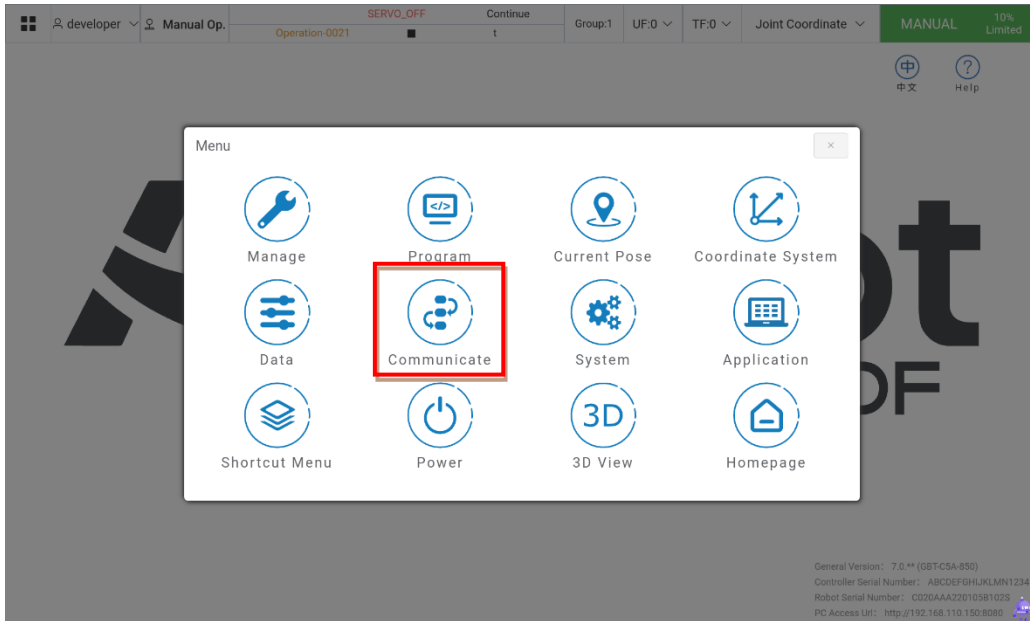

- (2) After opening the communication screen, click on the I/O status to view the I/O signal as shown in the following figure.

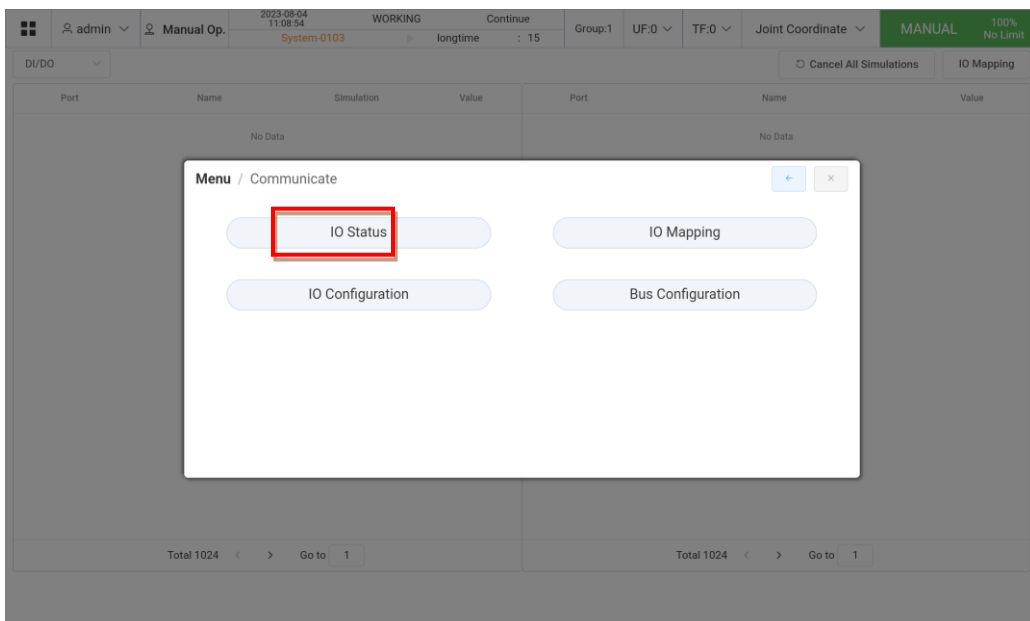

- (3) After opening the I/O status screen, click on the part in the circle to view different types of signals as

shown in the following figure.

Port	Name	Simulation	Value	Port	Name	Value
RO[1]	robot_arm1	UnSim Sim	OFF	RO[1]	robot_arm7	OFF
RO[2]	robot_arm2	UnSim Sim	OFF	RO[2]	robot_arm8	OFF
RO[3]	robot_arm3	UnSim Sim	OFF	RO[3]	robot_arm9	OFF
RO[4]	robot_arm4	UnSim Sim	OFF	RO[4]	robot_arm10	OFF
RO[5]	robot_arm5	UnSim Sim	OFF	RO[5]	robot_arm11	OFF
RO[6]	robot_arm6	UnSim Sim	OFF	RO[6]	robot_arm12	OFF

(4) UI1, UI2 and UI5 signals should be normally off as shown in the following figure.

Port	Name	Bypass	Value	Port	Name	Value
UI[1]	Servo_Enable	Yes No	ON	UI[1]	CMD_Enable	OFF
UI[2]	Pause_Request	Yes No	ON	UI[2]	Paused	OFF
UI[3]	Reset	Yes No	OFF	UI[3]	Fault	OFF
UI[4]	Start&Restart	Yes No	OFF	UI[4]	Program_Running	ON
UI[5]	Abort_Program	Yes No	ON	UI[5]	Servo_Status	ON
UI[6]	Selection_Strobe	Yes No	OFF	UI[6]	Selection_Check_Request	OFF
UI[7]	MPLCS_Start	Yes No	OFF	UI[7]	MPLCS_Start_Done	OFF
UI[8]	Program_Selection_1	Yes No	OFF	UI[8]	Selection_Confirm_1	OFF
UI[9]	Program_Selection_2	Yes No	OFF	UI[9]	Selection_Confirm_2	OFF
UI[10]	Program_Selection_3	Yes No	OFF	UI[10]	Selection_Confirm_3	OFF

Safety-2115 - The safety board dual channel data are not the same.*

Phenomenon: The safety board dual channel data are not the same.

Result: ESTOP status

Cause: error in hardware signal

Countermeasure: Check if the safety circuit on the safety board is normal.

Safety-2116 - The safety board detects external stop signal.*

Phenomenon: The safety board detects external stop signal.

Result: ESTOP status

Cause: status of hardware signal

Countermeasure: Check external ESTOP signal.

Safety-2117 - The safety board detects safety door stop signal.*

Phenomenon: The safety board detects safety door stop signal.

Result: ESTOP status

Cause: status of hardware signal

Countermeasure: Check safety door signal.

Safety-2118 - The safety board detects limited stop signal.*

Phenomenon: The safety board detects limited stop signal.

Result: ESTOP status

Cause: status of hardware signal

Countermeasure: Check the limit signal.

Safety-2119 - The safety board detects Deadman Normal is abnormal when in manual mode.*

Phenomenon: The safety board detects that Deadman Normal is releases in manual mode.

Result: E-STOP status

Cause: status of hardware signal

Countermeasure: Check if the Deadman button is pressed in the manual mode.

Safety-2122 – The safety board detects TP E-STOP signal.*

Phenomenon: The safety board detects TP E-STOP signal.

Result: E-STOP status

Cause: status of hardware signal

Countermeasure: Check the TP E-STOP button.

System-2193 - Controller detects the safety board is not ready when reset operation*

Phenomenon: The robot cannot be powered on after RESET is pressed.

Result: The operation fails.

Cause: The safety board signal is not ready.

Countermeasure: Check the alarm codes reported simultaneously and the safety board signal

Motion-2110-Motion-2115 - Joint out of constraint* (Axis 1 - Axis 6)

Phenomenon: Joint out of constraint

Result: The program cannot run continuously. It is paused and should be reset.

Cause: Input joint value exceeds the constraint.

Countermeasure: Move the robot to within the soft limit position.

Perform the following operations when it exceeds the soft limit.

- 1) View current position message and soft limit position message of each axis.
- 2) Implement zero calibration due to the soft limit caused by the loss of zero calibration.

The operation steps are as follows for Case 1:

1. Click the menu and then current pose icon.

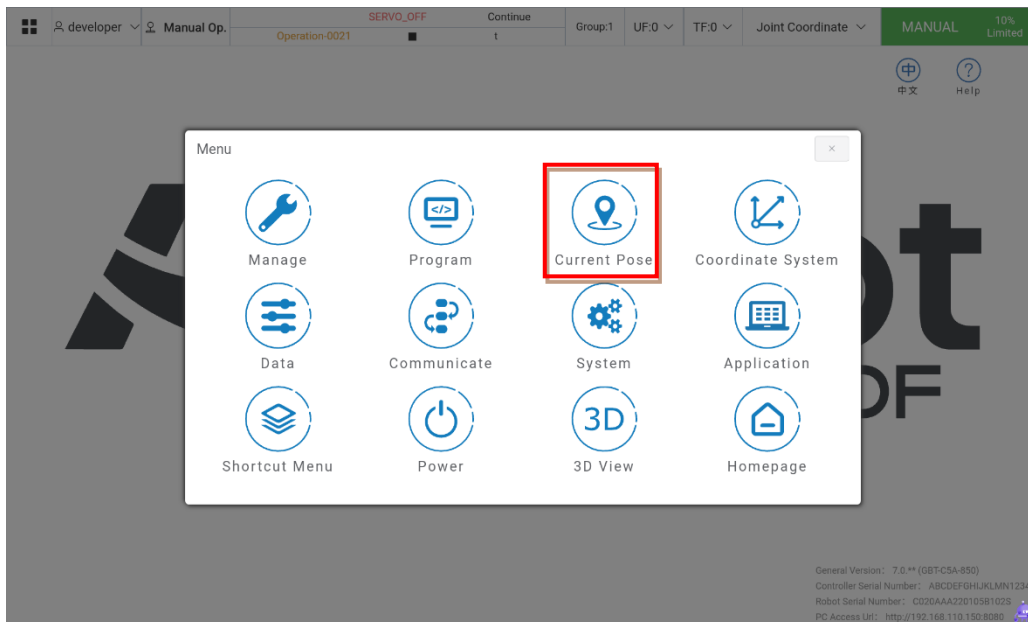

2. After selecting the current position icon, you can view the position information of each axis as shown in the following figure.

The screenshot shows the controller interface with the 'Position in Coordinate' dropdown set to 'Joint Coordinate'. The joint positions are as follows:

Joint	Position	Unit
J1:	0.001	°
J2:	89.994	°
J3:	-89.991	°
J4:	0.000	°
J5:	89.999	°
J6:	0.000	°
J7:	-	
J8:	-	
J9:	-	

The 'Target Pose' section shows input fields for joints J1 through J9, all currently set to 0. A 'Move to point' button is visible at the bottom, with a 'Moving' indicator.

- Switch relative coordinate systems to view the position information of each axis under different coordinate systems, as shown in the following figure.

The screenshot shows the same interface as above, but with the 'Position in Coordinate' dropdown menu open. The menu options are:

- Joint Coordinate
- Base Coordinate
- World Coordinate
- User Coordinate

The 'Joint Coordinate' option is currently selected. The joint positions are updated as follows:

Joint	Position	Unit
J1:		
J2:		
J3:		
J4:		
J5:	108.043	°
J6:	0.000	°
J7:	-	
J8:	-	
J9:	-	

The 'Target Pose' section and 'Move to point' button remain the same.

- Click on the system icon as shown in the figure below and then the Basic Setting to open the Soft Limit Setting screen.

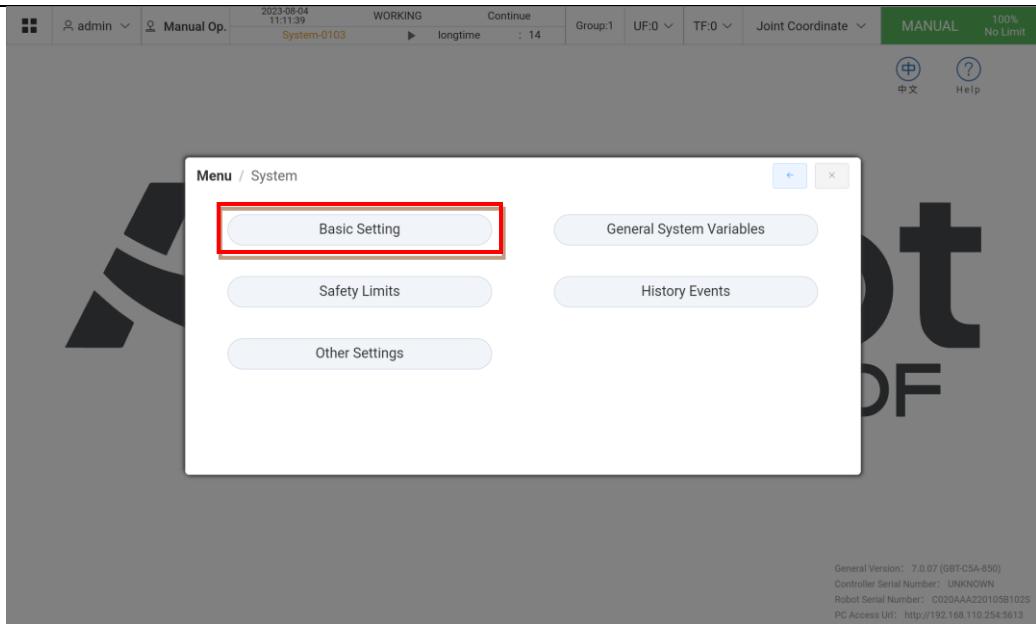

5. Click on the Soft Limit Setting to view the soft limit value of each axis.

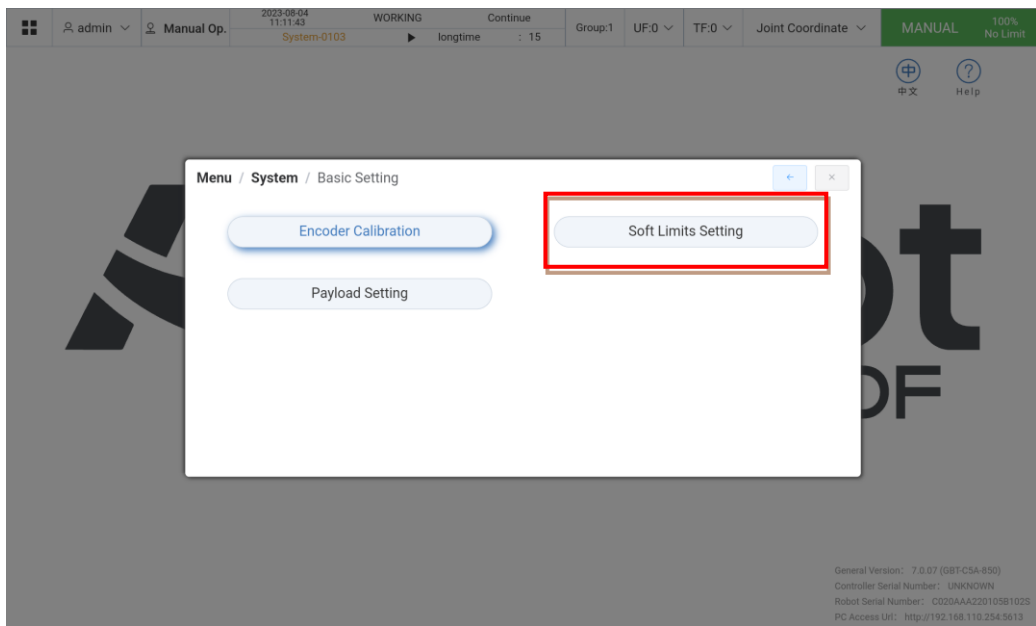

6. The following figure shows upper and lower limits of the soft limit of each axis.

Axis	Default lower	Lower Soft	Upper Soft	Default upper
Axis1	-360 °	-360 °	360 °	360 °
Axis2	-85 °	-85 °	265 °	265 °
Axis3	-161 °	-161 °	161 °	161 °
Axis4	-85 °	-85 °	265 °	265 °
Axis5	-360 °	-360 °	360 °	360 °
Axis6	-360 °	-360 °	360 °	360 °

The operation steps are as follows for Case 2:

1. The soft limit error may also be caused in case of loss of zero calibration. Click Basic Setting - Zero Setting to open the zero calibration screen. If the status is “uncalibrated”, it should be calibrated again.

<input type="checkbox"/>	Axis No.	Offset (°)	Status
<input type="checkbox"/>	Axis 1	0	Zero Lost
<input type="checkbox"/>	Axis 2	0	Zero Lost
<input type="checkbox"/>	Axis 3	0	Zero Lost
<input type="checkbox"/>	Axis 4	0	Zero Lost
<input type="checkbox"/>	Axis 5	0	Zero Lost
<input type="checkbox"/>	Axis 6	0	Zero Lost

2. A prompt message may appear in the upper right corner after calibration. Then, click "Save" below it to save the calibration information and then complete the calibration.

The screenshot shows the Agilebot calibration interface. At the top, there is a navigation bar with a hamburger menu, a user profile 'developer', and a mode selector 'Manual Op.'. The main area features a 'Method' dropdown set to 'General Calibration Method'. A table lists six axes with their respective offsets and statuses. A 'SUCCESS' notification box is visible in the top right corner, indicating that the calibration was successful. At the bottom, there are buttons for 'Temporary Masking Error', 'Reset Encoder', 'Cancel', and 'Save'.

Axis No.	Offset (°)	Status
Axis 1	0	Not Saved
Axis 2	0	Not Saved
Axis 3	0	Not Saved
Axis 4	0	Not Saved
Axis 5	0	Not Saved
Axis 6	0	Not Saved

5 REPLACEMENT OF UNITS



Warning

When units or printed circuit boards are replaced through maintenance and repair, turn off the circuit breaker and remove the power cord. Do not touch internal units or printed circuit boards in 1 min after the circuit breaker is turned off. It is only allowed in the safe state that surrounding machines or other devices are not moving.



Warning

When replacing parts, make sure to read the Maintenance Manual in advance and proceed with the operation after fully understanding the operating steps. Operations in wrong steps may lead to unexpected accidents, resulting in damage to the robot or injury to the operator.



Caution

Please note that the parts inside the controller may be hot. Heat-resistant gloves and other protective devices should be available when it is necessary to touch the equipment in a hot state.



Caution

- 1) When removing the printed circuit board, make sure to avoid touching the semiconductor parts on the circuit or other parts with hands. It is required to confirm that the settings for the printed circuit board to be replaced have been correctly made.
- 2) After replacement, correctly adjust the printed circuit board to be adjusted.
- 3) The replacement of the rear panel, power unit or main board (including base board and module) may sometimes result in the loss of robot parameters, teaching data, etc. Therefore, it is necessary to back up the data in the memory card in advance.
- 4) Re-mount the cables removed during replacement. If unable to figure out the joints, make appropriate records before removing the cables.

5.1 STEPS BEFORE REPLACEMENT

Disconnect the power supply of the controller.

- (1) Turn off the switch.
- (2) Remove the power cable.

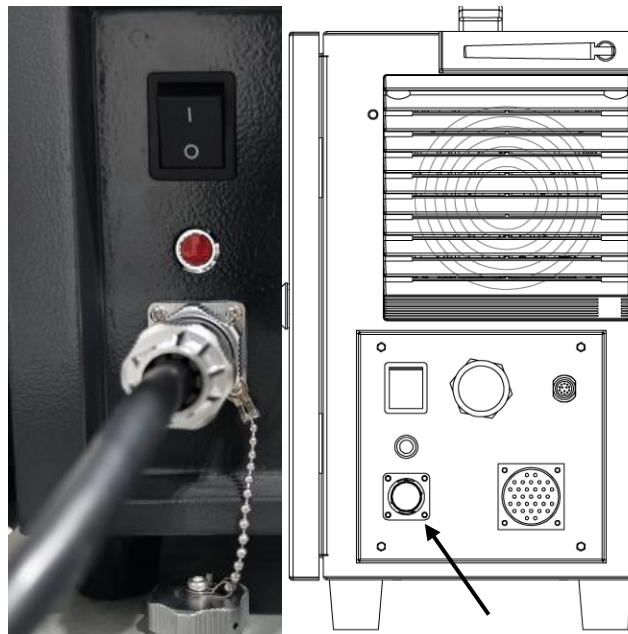

Power cable

Fig. 5.1 Power inlet

- (3) Open the front panel of the Controller using a tri-wing key to remove the cover.
- (4) For replacement of related components, refer to the Maintenance Manual.

6 HANDLING AND MOUNTING

6.1 HANDLING METHOD

When moving the Controller, simply lift it by the handle at the upper end. When lifting, ensure the center of gravity of the Controller is balanced to avoid unnecessary stress on your hands and body. When it comes to packaging and transportation, it should be packaged in accordance with the packaging standards, and the required markings should be affixed outside the packaging box.

The Controller packaging box should be lifted using the handles on both sides.

After the transportation is completed, keep the original packaging intact. Store the packaging materials in a dry place in case you need to repackage and move the robot in the future.



Warning

Use appropriate lifting equipment. Shanghai JBT Robot Co., Ltd. is not responsible for the damages occurring during the transportation of the equipment.

Please comply with the relevant handling regulations in various regions and countries.

Ensure that the installation instructions are strictly followed when installing the robot.



Caution

All warranties will be void if the robot is transported without using its original packaging

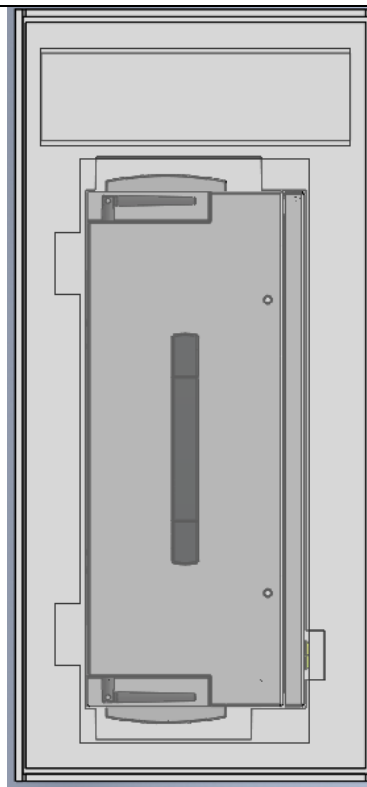

6.2 MOUNTING METHOD



Fig. 4.3 Mounting of Controller

- If mounted on a desktop (without a rack), the controller requires 100mm free space on both sides.
- The controller requires 200mm free space on the back to ensure proper cooling. Never place the customer's cable on the fan cover on the back of the controller. Otherwise, it may inspection difficult and result in insufficient cooling.



Caution

Please ensure the above areas for the purpose of maintenance and heat dissipation.

Please mount the controller in a well-ventilated and open space. Mounting in a closed space may cause such issues as ineffective cooling, high temperature, lower reliability or malfunction of the controller.

6.3 MOUNTING CONDITIONS

The IRC-D6B controller may not intentionally generate/use high-frequency energy of wireless bandwidth in the combined electromagnetic, inductive or capacitive form. Except for ordinary household devices directly connected to low-voltage networks, this controller can be used for induction and radiation barriers in material handling/investigation/analysis facilities. In non-industrial environments, its electromagnetic compatibility may sometimes be problematic. Never use this device in residential areas.

Otherwise, it may cause malfunctions. In order to prevent interference with users' reception of radio and television signals, it cannot be used unless special measures are taken to reduce electromagnetic radiation. This device may not malfunction due to harmonics generated in general factory environments, but it may malfunction when connected to a distorted power source containing higher harmonics. In this case, please take harmonic countermeasures for the power device.

Item	Requirements
Operating temperature	0-50°C
Protection level	IP54

6.4 ADJUSTMENT AND CONFIRMATION ITEMS DURING MOUNTING

Item	Contents
1	Check internal and external appearance of the controller.
2	Check if the fixing screw terminals have been properly connected.
3	Confirm the insertion status at mounting positions of connectors and printed circuit board.
4	Connect the cables of the controller and the mechanism.
5	Switch off the circuit breaker and connect the input power cable.
6	Confirm the input power voltage.
7	Confirm the port signal between the controller and the robot mechanism.
8	Confirm and set all parameters.
9	Confirm the motion of each axis under manual feed.
10	Confirm the conditions of control port signals of peripheral devices.

APPENDICE

A.MEANING OF CONTROL SYSTEM I/O SIGNALS OF PERIPHERAL DEVICES

The following table lists the system I/O signals for the ports of the peripheral devices on IRC-D6B.

List of UI/UO signals					
UI[1]	Servo_Enable Servo enable signal (it can be used as an alarm signal of instantaneous stop peripheral software; or after pausing, it turns off the servo-holding brake to make a complete stop)	Servo_Enable is usually ON. When the peripheral upper computer does not want the robot to move or when power is switched on, it is switched to OFF. It is used for safety locking. In the OFF state, the system performs the following processing: 1. Issue an alarm and then disconnect the servo power supply. 2. Instantly stop the robot (Cat. 0 stop) and suspend the execution of the program. 3. The servo cannot always be enabled. The bypass is ON.	UO[1]	CMDENBLE Allow peripheral devices to control the status signals of the robot.	Output high level when the following conditions are met (this signal at high level indicates that it is allowed to use the <i>Program Start Method in Auto Mode</i> to start the sequence or pause recovery, based on whether it is currently Paused): 1. The running status of the robot is "On-Standby". 2. It is in "Auto" mode. 3. The "Single Step" or "Reverse" is not selected as the program execution mode.
UI[2]	Pause_Request	Pause signal. It is usually ON. In the OFF state, the system performs the following processing: It is planned to slow down and stop the executing action and to suspend the execution of the program. The bypass is ON.	UO[2]	Paused	"Paused" status signal. When the program execution status is "Paused", this signal is ON (i.e. the robot is paused).
UI[3]	Reset Alarm reset signal	Release the alarm, power on the servo and effectively generate a Reset request at a high level.	UO[3]	FAULT	When an alarm occurs in the system, this alarm signal is output and can be reset by RESET. Note: This signal is not output when the system issues a warning type alarm.
UI[4]	Start & Restart Program launch/resume signal	Start or restart the program (depending on whether the program status is "Aborted" or "Pause") and its function is the same as the Start button on Control handle. Take the effective falling edge to start or restart the program.	UO[4]	Program Running Program running signal	ON indicates that the program is running; OFF indicates that no program is running.
UI[5]	Abort Program Program abort signal	Request to terminate a program in execution or paused state. It is usually ON. In the OFF state, the system performs the following processing: The alarm bar indicates a program abort request and the program enters the abort mode. If the program is still running, immediately stop the robot's action	UO[5]	Servo Status	This signal is set to high level when the robot operation status is "Working", "On Standby" or "Servo ON". It is at lower level under "Servo-OFF".

List of UI/UO signals					
		and then abort the program. It is similar to an "aborted" alarm. Allow to enable and teach the servo, but not to manually or automatically execute programs. The bypass is ON.			
UI[6]	Selection Strobe Trigger signal	It is only valid when the "Program Launch Mode" is set to "MPLCS" or "MPLCS Simple Trigger". Read the trigger signal for selecting the program to be executed. When it is ON, read the input of Program Selection 1-6 and select the program to be executed. Note: This signal is ignored when a program is executing (running or paused).	UO[6]	Selection Check Request	It is only valid when the "Program Launch Mode" is set to "MPLCS" or "SMPLCS Simple Mode".
UI[7]	MPLCS Start	It is only valid when the "Program Launch Mode" is set to "MPLCS" or "MPLCS Simple Trigger". It is a start signal of program number selection.	UO[7]	MPLCS Start Done	It is only valid when the "Program Launch Mode" is set to "MPLCS" or "MPLCS Simple Trigger".
UI[8]-UI[13]	Program Selection 1-6	It is only valid when the "Program Launch Mode" is set to "MPLCS" or "MPLCS Simple Trigger". The 6-digit binary number of the program number is converted to a decimal number, which is the start number of the main program to be executed.	UO[8]-UO[13]	Selection Confirm 1-6	It is only valid when the "Program Launch Mode" is set to "MPLCS" or "MPLCS Simple Trigger". After receiving the Selection Strobe signal, the robot controller may read the status of UI[8]-UI[13] and feed it back to the upper level for confirmation.
UI[14]	Drag mode Signal	When the input level is high, the robot enters a dragable state. If the robot is in a state where dragging is not allowed, the input is ignored.			

B. SPARE PARTS

Teach pendant		
Material Name	Material number	Model and specification description
Operating handle	2110000008	GBT-HHT7X11E; Operating handle; Cable length: 5m; With magnetic suction; IP54 protection level; Suitable for the collaborative robot series
Operating handle	2110000010	GBT-HHT7X11E; Operating handle; Cable length: 10m; With magnetic suction; IP54 protection level; Suitable for the collaborative robot series
Operating handle	2110000011	GBT-HHT7X11E; Operating handle; Cable length: 20m; With magnetic suction; IP54 protection level; Suitable for the collaborative robot series

Controller power cable		
Material Name	Material number	Model and specification description
Controller power cable	2010300062	Power cable; 5 meters in length; AC220V; 10A; Used for AC OEM cabinets; Injection-molded connector;
Controller power cable	2010300061	Controller power cable, 2010300061, Power cable; 5 meters in length; AC220V; 10A; Used for standard cabinets; Injection-molded connector; Standard aviation plug;

Controller		
Product name	Material number	Model and specification description
Tail cable of the operating handle	2010300058	GBT-HHT0DA1E; Pre-fabricated cable for the socket inside the cabinet; Cable length: 0.7m; Pre-fabricated with TE-D1200 terminal; Tail cable matched with the operating handle.
Button battery	2020400021	Panasonic button battery; Model: CR2032; Rated voltage: 3V.
DC fuse	2020100011	29707.5WXNV; Rated current: 7.5A; 32VDC.
Switching power supply	2020400022	Switching power supply; Flat panel installation; 220VAC; 48VDC/13A.
Toggle switch	2020500028	Toggle switch; 250VAC; 1 normally open (NO) / 1 normally closed (NC); Dimensions: 30.5*25.5.
Metal indicator light	2020500035	AD103-12J/R23; DC24V; Red in color; IP65 protection level; Without built-in light; Flat head; Diameter: ϕ 12.
Router core board	2020600051	Router core board
External antenna,	2020600053	Small cigarette rod antenna
Fan accessory	2020600083	ZL-803; Fan filter screen; Louver filter screen; Dimension: 120*120; Protection level: IP54
Fan	2020600084	R1225X24BPLB1c-7; Fan; Dimension: 120x120x25; 24VDC
Panel-mounted interface	2030100002	RJ45F71; Ethernet RJ45 interface
AP processor board	2110000009	Core board
Cable inside the single-phase power cabinet	4010300002	SN-2019-GBT-030; Cable inside the 220V power cabinet; Single-phase; 3x2.5mm ² ; Length: 0.3m
Heavy-duty pre-fabricated cable inside the IRC-D6B cabinet	4010300035	Heavy-duty pre-fabricated cable inside the cabinet
Main board of the collaborative robot Controller V9.4,	404AP_CMB00904_E0002	AP_CMB00904_E/250x120MM/V0.2
Bus power board of the collaborative robot V3.4	404AP_PMB00304_E0002	AP_PMB00304_E/140x140mm/V0.2
Sub-board A of the power board	404AP_PSA00100_E0001	AP_PSA00100_E/130x130mm/V0.1
Plug-in terminal block	2030400025	15EDGKNHB - 3.5 - 10P; Plug-in female terminal block; Spring terminal10P; Green; Spacing3.5mm; AWG16 - 28

Controller		
Product name	Material number	Model and specification description
Plug-in terminal block	2030400026	15EDGKNHB - 3.5 - 16P; Plug-in female terminal block; Spring terminal16P; Green; Spacing3.5mm; AWG16 - 28
Plug-in terminal block	2030400027	15EDGKNHB - 3.5 - 08P; Plug-in female terminal block; Spring terminal8P; Green; Spacing3.5mm; AWG16 - 28
Plug-in terminal block	2030400028	15EDGKNHB - 3.5 - 20P; Plug-in female terminal block; Spring terminal20P; Green; Spacing3.5mm; AWG16 - 28
Plug-in terminal block	2030400029	15EDGKNHB - 3.5 - 12P; Plug-in female terminal block; Spring terminal12P; Green; Spacing3.5mm; AWG16 - 28
Plug-in terminal block	2030400030	15EDGKNHB - 3.5 - 04P; Plug-in female terminal block; Spring terminal4P; Green; Spacing3.5mm; AWG16 - 28
Short-circuit bar	2120200029	ZQV 1.5N/2; Commodity number 1985410000; Short-circuit bar; 2 cores; Center distance: 3.5mm; Orange color

Contact us

Agilebot Robotics Co., Ltd. (Shanghai Headquarters):

7F, Building T1, Hongqiao Wanchuang Center, Lane 500, Xinlong Road, Minhang District, Shanghai, China

Agilebot Operation and Technical Service Center:

Building 1, No. 338 Jiuye Road, Qingpu District, Shanghai

Service hotline: +86-21-5986 0805

Website: www.sh-agilebot.com